

PRESSURE

The correct pressure for the buoyancy tube is 200 mb/3.0 PSI.

We recommend that you purchase a pressure indicator from your Dealer. This will permit a quick and efficient control of the pressure during inflation. Without a pressure indicator, stop inflating when the foot-pump gets difficult to operate, and the boat is « hard » (you should not be able to bend the cone ends).

Ambient temperature of air and water have an effect on the boat's internal pressure

| Ambient temperature | tubes' internal pressure |
|---------------------|--------------------------|
| +1°C / +1,8°F | +4 mb / 0,06 PSI |
| -1°C / -1,8°F | -4 mb / 0,06 PSI |

Therefore, it is important to anticipate:

Because of temperature variations (especially when this variation is important between the beginning and the end of the day, in hot areas) check and adjust the pressure in the inflated compartments by inflating or deflating. Be sure that pressure remains within the recommended zone, between 170 mb/2.5 PSI and 220 mb/3,5 PSI.

RISK OF UNDERPRESSURE

EXAMPLE: Your boat is in direct sunlight on the beach (temperature =50°C/122°F) at recommended pressure (200 mb/3.0 PSI). After putting it in the colder water (temperature =20°C/68°F), the internal temperature and pressure of the tubes will both drop (up to 85 mb/1.8 PSI) and **YOU WILL HAVE TO INFLATE AGAIN** until you regain the lost pressure due to the difference in temperatures. Therefore, a loss of pressure at the end of the day, when ambient temperature drops, is perfectly normal.

NOTE :

Proper inflation is critical to the performance of the boat. It is the pressure in the tubes that gives your boat the necessary rigidity to perform well. Under-inflation causes improper flexing of the tubes which will result in stress and chafe

RISK OF OVERPRESSURE

EXAMPLE: Your boat is inflated to the recommended pressure (200 mb/3.0 PSI) at the beginning of the day (low ambient temperature =10°C/50°F). Later in the day, your boat is in direct sunlight on the beach or on a yacht's deck (temperature =50°C/122°F). Internal temperature of all inflated compartments can then increase and reach up to 70°C/158°F (especially for dark-coloured tubes). The consequence will be a doubling of previous pressure (400 mb/6.0 PSI). **YOU WILL THEN HAVE TO DEFLATE** until you reach the recommended pressure.



WHEN YOUR BOAT IS OVER INFLATED, PRESSURE BECOMES TOO STRONG FOR THE INFLATABLE STRUCTURE, AND COULD CAUSE A BREAK IN THE FABRIC ASSEMBLY

IN CASE OF OVERPRESSURE

SEMI-RECESSED VALVE :

Deflate by pressing the spring loaded button.

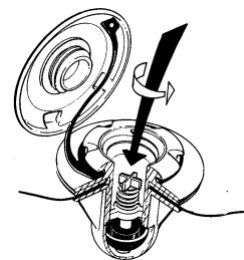

ASSEMBLY OF STANDARD EQUIPMENT

STOWING THE OARS (EXTERNALLY)

(The oars can be stowed either inside or outside the buoyancy tube).

NOTE :

Always untie the toggles before rowing.

- Pass the oar blade through the rear handle strap (item 1).
- Twist the elasticated toggles around the oar shaft (item 2).

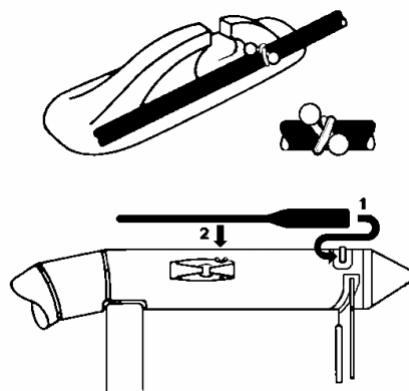

STOWING THE OARS (INTERNALLY)

- Fixing straps are provided on the inside of the buoyancy tube.

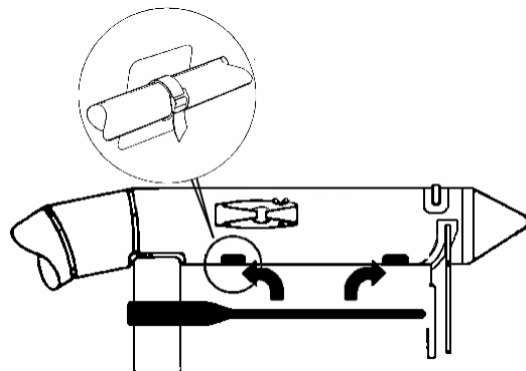

FITTING THE SEAT

- Slide one end of the seat into the corresponding seat patch on the buoyancy tube.
- Pull the seat towards the otherside of the boat.
- Slide the opposite end of the seat in the other seat retaining patch.

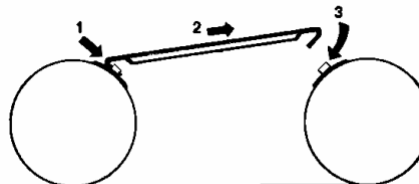

ALWAYS CHECK THAT THE SEAT IS SECURELY FITTED BEFORE USE.

FITTING THE DECK DRAIN PLUG

- To fit the deck drain plug (item 1) push into the sleeve (item 2) in the transom.
- To lock in position push handle through 90° as shown by the arrow.

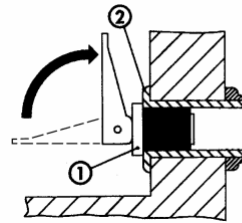

ALWAYS CHECK THAT THE DRAIN PLUG IS SECURELY FITTED BEFORE LAUNCHING THE BOAT.

NOTE :

For boats equipped with an Air deck the drain plug must be fitted from the outside of the transom. This will prevent the deck being damaged by rubbing against the drain plug

DEFLATING / FOLDING THE BOAT

- **Remove** oars and equipment.
- **Remove** the deck
- **Empty** the boat of all water and sand by opening the drain plug and allow to dry.
- **Deflate** the boat.
- **Fold in** the 2 sides of the main buoyancy tube (A), fold the cones onto the transom, then **roll up** the boat around the transom (C). Start again if you feel there is still some air left in the tubes.

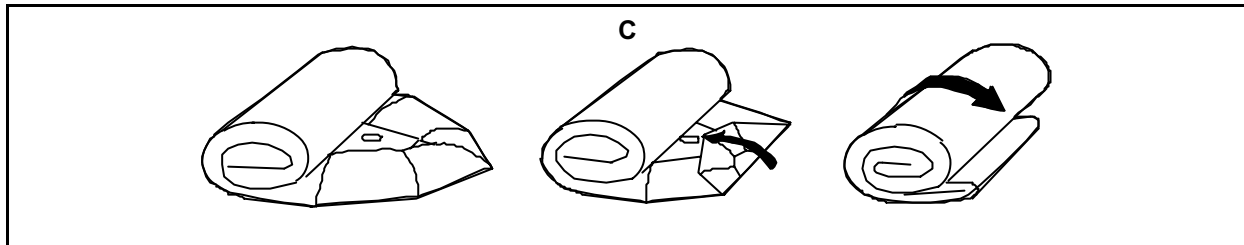
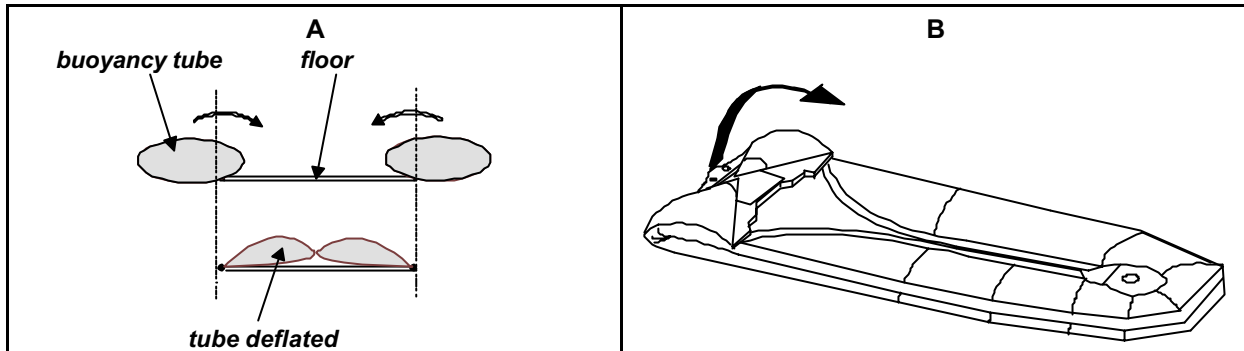

- **Stow** the boat in its bag (D).
- **Position** the dismantled oars on top.
- **Close** the bag by pulling the end flaps towards each other, secure the tie tapes and then pull the top flap over to secure the tie tapes at the side, ensuring all equipment stays inside.
- **To finish**, also store the foot-pump in the bag.

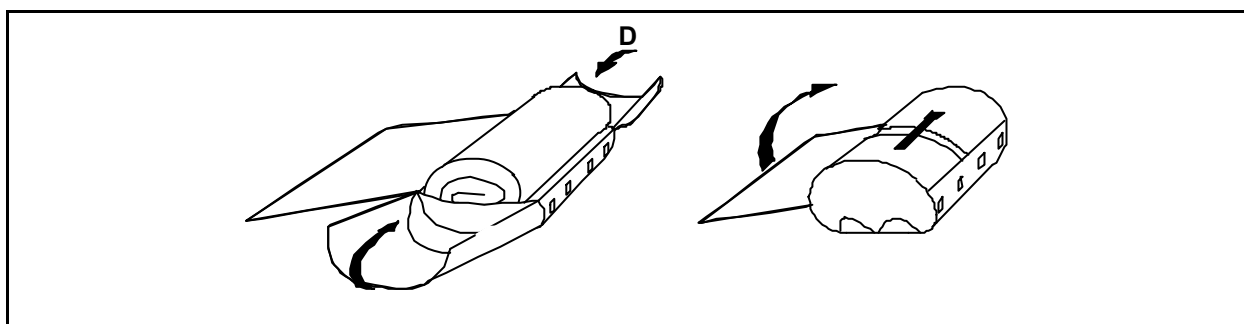

STORAGE

Prior to storage for long period (for example, over the winter) it is advisable to clean the boat thoroughly. The deck should also be removed so that the fabric floor of the boat can be cleaned.

REMOVING THE SLATTED DECK (250 COMPACT ONLY)

- Remove all standard equipment from the boat.
- Fully deflate the boat.
- Slide the forward deck slat out of the retaining loops on the fabric floor.
- Slide the rear deck slat out of the retaining loops on the fabric floor.
- Remove the deck.
- For deck installation reverse the above procedure.

REMOVING THE AIR DECK (250 / 280 / 310 / 340 AIR ONLY)

- Remove all standard equipment from the boat.
- Fully deflate the boat and deck.
- Starting at the bow of the boat pull the Air Deck out of the reinforced area between the fabric floor and the buoyancy tube.
- Fold the deck over the transom to access the fabric floor of the boat for cleaning.
- The deck can be completely removed from the boat by loosening the screws holding the deck flap clips against the transom.
- For deck installation reverse the above procedure.

NOTE :

To avoid damage to the Air Deck the transom drain plug must be fitted from the outside of the transom.

NOTE :

If the transom clip screws are removed from the transom then the transom must be sealed with a marine grade sealant when the clip is refitted. This prevents the ingress of water into the transom, which could otherwise cause severe damage.

REMOVING THE ROLL AWAY DECK (280 / 310 / 340 ROLL AWAY ONLY)

- Remove all standard equipment from the boat.
- Starting at the bow of the boat pull the Roll Away Deck out of the reinforced area between the fabric floor and the buoyancy tube.
- Fold the deck over the transom to access the fabric floor of the boat for cleaning.
- The deck can be completely removed from the boat by loosening the screws holding the deck flap clips against the transom.
- For deck installation reverse the above procedure.

NOTE :

If the transom clip screws are removed from the transom then the transom must be sealed with a marine grade sealant when the clip is refitted. This prevents the ingress of water into the transom, which could otherwise cause severe damage.

DECLARATION OF CONFORMITY

Rover 250 Compact / Air
Rover 280 Solid / Roll Away / Air
Rover 310 Solid / Roll Away / Air
Rover 340 Solid / Roll Away / Air

DECLARATION OF CONFORMITY TO DIRECTIVE 94/25/EC

Avon Inflatables Limited declares that the boats cited in the above heading conform to the essential safety requirements of the above directive and to the international standards: - ISO 6185, ISO EN 10087.

DECLARATION DE CONFORMITE A LA DIRECTIVE 94/25/EC

Avon Inflatables Limited declare que les bateaux cit en rubrique conforme aux règlements essentiels de sécurité de la directive citée ci-dessus at aux normes internationales:- ISO 6185, ISO EN 10087.

ERKLÄRUNG DER KONFORMITÄT ENTSPRECHEND RICHTLINIE 94/25/EC

Avon Inflatables Limited erklärt hiermit, daß die o.a. Boote die Anforderungen der obigen Richtlinie erfüllen und mit den folgenden internationalen Standards übereinstimmen:- ISO 6185, ISO EN 10087.

DECLARATION DE CONFORMIDAD A LA DIRECTIVA 94/25/EC

Avon Inflatables Limited declara que los barcos arriba mencionado en el título se ajusta a las normas de seguridad esenciales de la directiva arriba escrita y a las especificaciones internacionales:- ISO 6185, ISO EN 10087.

DICHIARAZIONE DI CONFORMITA' ALLA DIRETTIVA 94/25/EC

Avon Inflatables Limited dichiara che i natanti sopra indicati sono conformi ai requisiti essenziali di sicurezza di cui alla citata direttiva e alle norme internazionali:- ISO 6185, ISO EN 10087.

Paul Hill. QA Manager

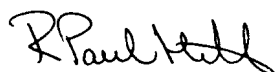

Avon Inflatables Limited, Dafen, Llanelli, Carmarthenshire SA14 8NA, UK